

## FEATURES

| for general purpose application, darlington transistor



## MECHANICAL DATA

| SOT-23 small outline plastic package

| Epoxy UL: 94V-0

| Mounting position: Any

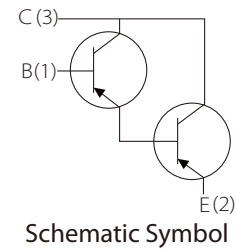

## APPROVALS

<b>RoHS</b>	Compliance with 2011/65/EU
<b>HF</b>	Compliance with IEC61249-2-21:2003

## MAXIMUM RATINGS (T<sub>A</sub> = 25°C )

Parameter	Symbol	Value	Unit
Collector-Base Voltage	V <sub>CBO</sub>	-30	V
Collector-Emitter Voltage	V <sub>CEO</sub>	-30	
Emitter-Base Voltage	V <sub>EBO</sub>	-10	
Collector Current	I <sub>C</sub>	-500	mA
Power Dissipation	P <sub>tot</sub>	200	mW
Junction Temperature	T <sub>j</sub>	150	°C
Storage Temperature Range	T <sub>STG</sub>	-55~+150	°C

## ELECTRICAL CHARACTERISTICS (T<sub>A</sub>=25°C)

Parameter	Symbol	Test Conditions		Min.	Typ.	Max.	Unit
DC Current Gain	h <sub>FE</sub>	MMBTA63	V <sub>CE</sub> =-5V, I <sub>C</sub> =-10mA	5000			V
		MMBTA64	V <sub>CE</sub> =-5V, I <sub>C</sub> =-10mA	10000			
		MMBTA63	V <sub>CE</sub> =-5V, I <sub>C</sub> =-100mA	10000			
		MMBTA64	V <sub>CE</sub> =-5V, I <sub>C</sub> =-100mA	20000			
Collector Cutoff Current	I <sub>CBO</sub>	V <sub>CB</sub> =-30V				-100	nA
Emitter Cutoff Current	I <sub>EBO</sub>	V <sub>EB</sub> =-10V				-100	
Collector Emitter Breakdown Voltage	V <sub>(BR)CEO</sub>	I <sub>C</sub> =-100μA		-30			V
Collector Emitter Breakdown Voltage	V <sub>CE(sat)</sub>	I <sub>C</sub> =-100mA, I <sub>B</sub> =-0.1mA				-1.5	
Base-emitter saturation voltage	V <sub>BE(on)</sub>	V <sub>CE</sub> =-5V, I <sub>C</sub> =-100mA				-2	
Transition Frequency	f <sub>T</sub>	V <sub>CE</sub> =-5V, I <sub>E</sub> =10mA		125			MHz

## TYPICAL CHARACTERISTICS

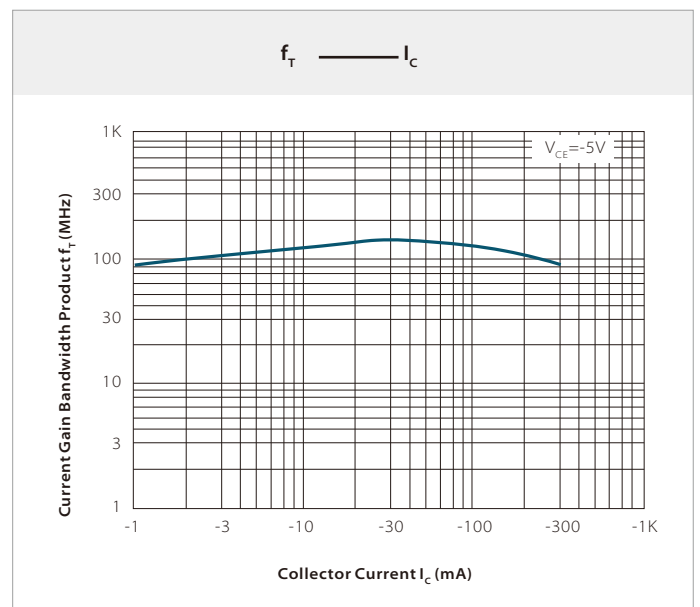
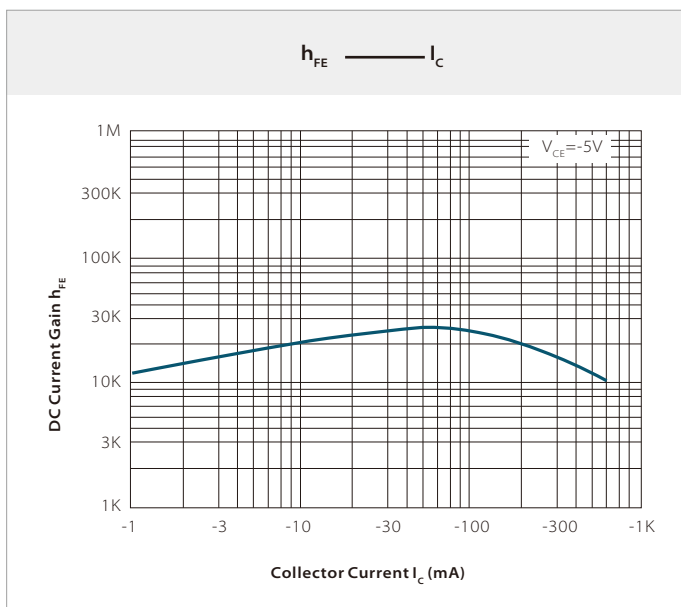

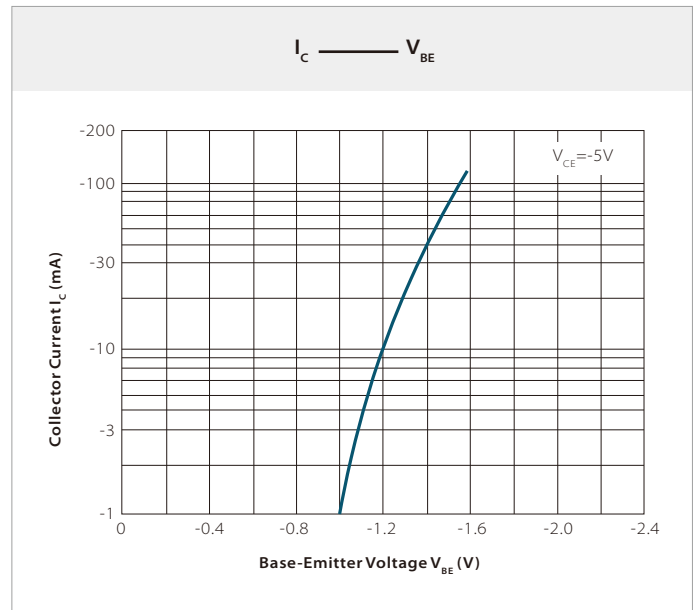
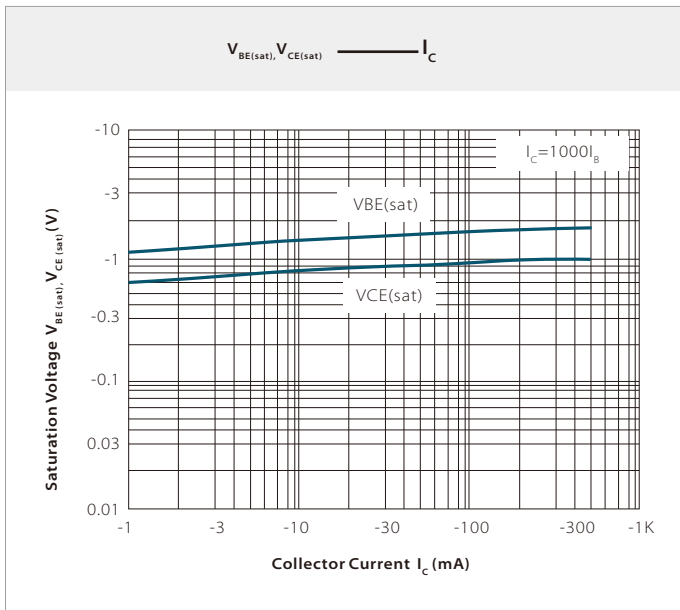

## SOLDERING PARAMETERS

Reflow Condition		Lead-free assembly
Pre Heat	Temperature Max ( $T_{s(min)}$ )	150°C
	Temperature Max ( $T_{s(max)}$ )	200°C
	Time (min to max) ( $t_s$ )	60 – 180 secs
Average ramp up rate (Liquidus Temp ( $T_L$ ) to peak)		3°C/second max
$T_{s(max)}$ to $T_L$ - Ramp-up Rate		3°C/second max
Reflow	Temperature ( $T_L$ ) (Liquidus)	217°C
	Time (min to max) ( $t_r$ )	60 – 150 seconds
Peak Temperature ( $T_p$ )		260°C
Time within 5°C of actual peak Temperature ( $t_p$ )		20 – 40 seconds
Ramp-down Rate		6°C/second max
Time 25°C to peak Temperature ( $T_p$ )		8 minutes max.
Do not exceed		260°C

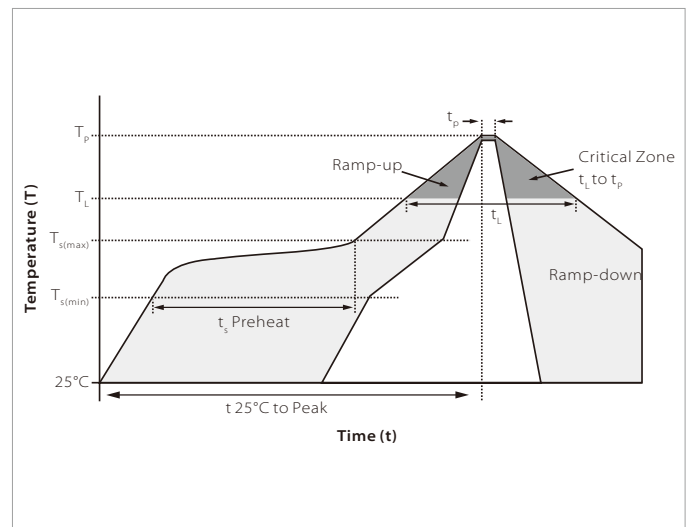

## SOT-23 PACKAGE INFORMATION

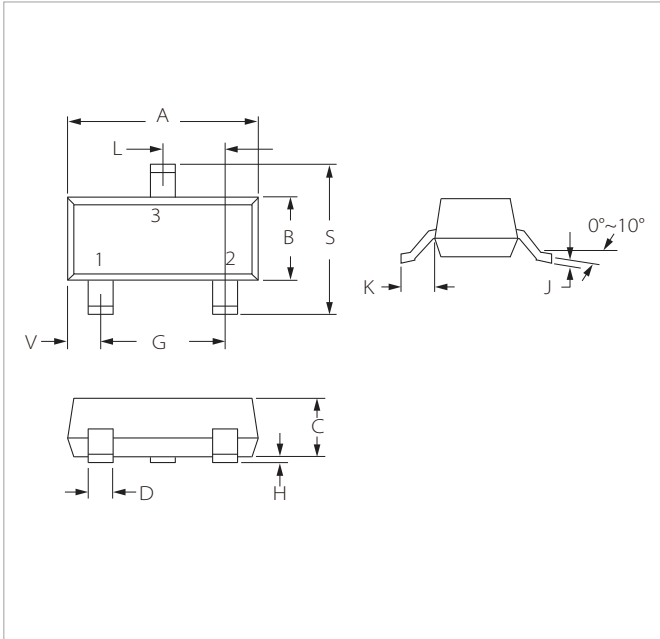

Ref.	Millimeters		Inches	
	Min.	Max.	Min.	Max.
A	2.80	3.04	0.110	0.120
B	1.20	1.40	0.047	0.055
C	0.89	1.11	0.035	0.044
D	0.37	0.50	0.015	0.020
G	1.78	2.04	0.070	0.081
H	0.01	0.100	0.001	0.004
J	0.085	0.180	0.003	0.007
K	0.35	0.69	0.014	0.029
L	0.89	1.02	0.035	0.040
S	2.10	2.64	0.083	0.104
V	0.45	0.60	0.018	0.024

## RECOMMENDED PAD LAYOUT DIMENSIONS

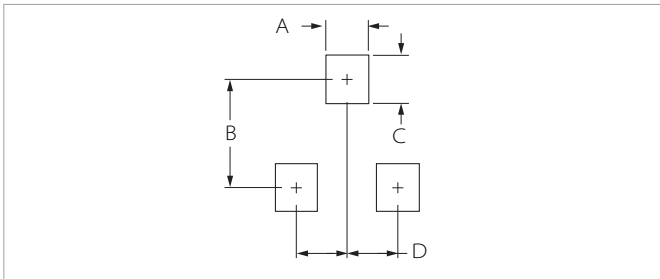

Ref.	Millimeters		Inches	
	Min.	Max.	Min.	Max.
A	0.71	0.97	0.028	0.038
B	1.88	2.13	0.074	0.084
C	0.71	0.97	0.028	0.038
D	0.81	1.07	0.032	0.042

## ORDERING INFORMATION

Part Number	Marking	Component Package	QTY/Reel	Reel Size
MMBTA63	2U	SOT-23	3000PCS	7"
MMBTA64	2V			

To find your local partner within Semiwell's website : [www.semiwell.com.cn](http://www.semiwell.com.cn)

©2023 Semiwell Microelectronics Co.,Ltd.

The content of this document has been carefully checked and understood. However, neither Semiwell nor its subsidiaries assume any liability whatsoever for any errors or inaccuracies of this document and the consequences thereof. Published specifications are subject to change without notice. Product suitability for any area of application must ultimately be determined by the customer. In all cases, products must never be operated outside their published specifications. Semiwell does not guarantee the availability of all published products. This disclaimer shall be governed by substantive Chinese law and resulting disputes shall be settled by the courts at the place of business of Semiwell. Latest publications and a complete disclaimer can be downloaded from the Semiwell website. All trademarks recognized.