

FEATURES

- | Low equivalent on-resistance

- | Power Dissipation of 250mW

- | High Stability and High Reliability

MECHANICAL DATA

- | SOT-23 small outline plastic package

- | Epoxy UL: 94V-0

- | Mounting position: Any

APPROVALS

RoHS	Compliance with 2011/65/EU
HF	Compliance with IEC61249-2-21:2003

MAXIMUM RATINGS ($T_A=25^{\circ}\text{C}$)

Parameter	Symbol	Value	Unit
Collector-Base Voltage	V_{CBO}	80	V
Collector-Emitter Voltage	V_{CEO}	60	
Emitter-Base Voltage	V_{EBO}	5	
Collector Current-Continuous	I_C	1.0	A
Peak Pulse Current	I_{CM}	2.0	A
Collector Power Dissipation	P_C	250	mW
Thermal Resistance From Junction To Ambient	$R_{\theta JA}$	500	$^{\circ}\text{C}/\text{W}$
Junction Temperature	T_J	150	$^{\circ}\text{C}$
Storage Temperature	T_{STG}	-55~+150	$^{\circ}\text{C}$

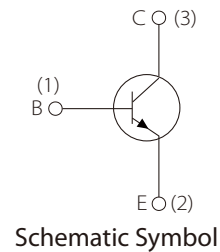
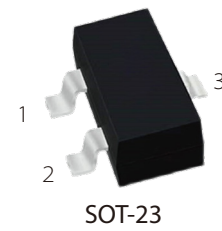

ELECTRICAL CHARACTERISTICS (T_A=25°C)

Parameter	Symbol	Test Conditions	Min.	Typ.	Max.	Unit
Collector-base breakdown voltage	$V_{(BR)CBO}$	$I_C=100\mu A, I_E=0$	80			V
Collector-emitter breakdown voltage	$V_{(BR)CEO}^*$	$I_C=10mA, I_B=0$	60			
Emitter-base breakdown voltage	$V_{(BR)EBO}$	$I_E=100\mu A, I_C=0$	5			
Collector cut-off current	I_{CBO}	$V_{CB}=60V, I_E=0$			100	nA
Emitter cut-off current	I_{EBO}	$V_{EB}=4V, I_C=0$			100	
DC current gain	$h_{FE(1)}$	$V_{CE}=5V, I_C=1mA$		100		
	$h_{FE(2)}^*$	$V_{CE}=5V, I_C=500mA$		100	300	
	$h_{FE(3)}^*$	$V_{CE}=5V, I_C=1000mA$		80		
	$h_{FE(4)}^*$	$V_{CE}=5V, I_C=2000mA$		30		
Collector-emitter saturation voltage	$V_{CE(sat)}^*$	$I_C=500mA, I_B=50mA$			0.25	V
		$I_C=1000mA, I_B=100mA$			0.50	
Base-emitter saturation voltage	$V_{BE(sat)}^*$	$I_C=1000mA, I_B=100mA$			1.10	
Base-emitter voltage	V_{BE}^*	$V_{CE}=5V, I_C=1000mA$			1.00	
Transition frequency	f_T	$V_{CE}=10V, I_C=50mA, f=100MHz$	150			MHz
Collector output capacitance	C_{ob}	$V_{CB}=10V, f=1MHz$			10	pF

* Measured under pulsed conditions, Pulse width=300us, Duty cycle≤2%

TYPICAL CHARACTERISTICS

Static Characteristic

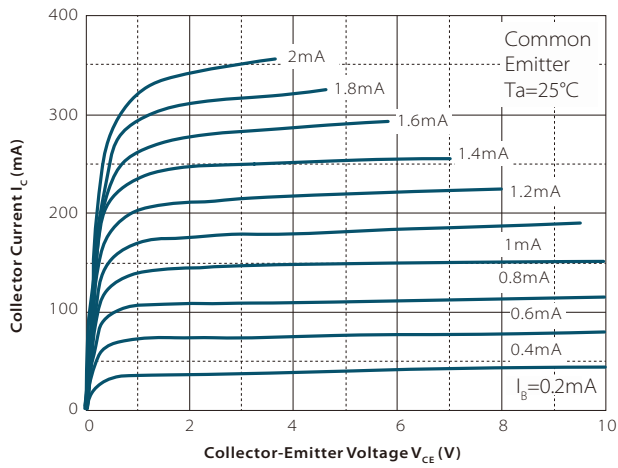

h_{FE} — I_C

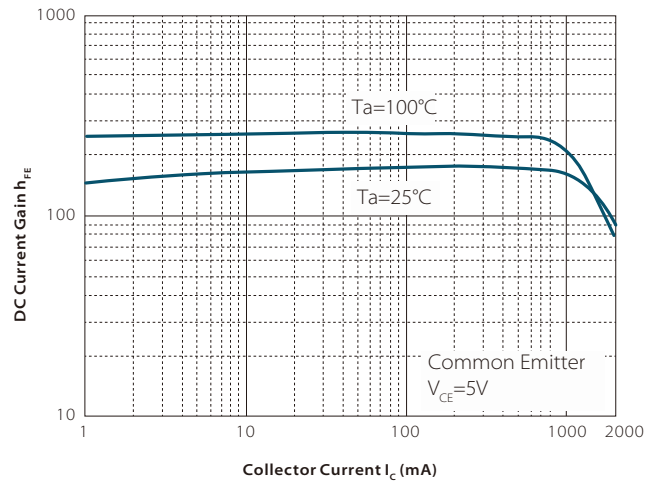

$V_{CE\text{sat}}$ — I_C

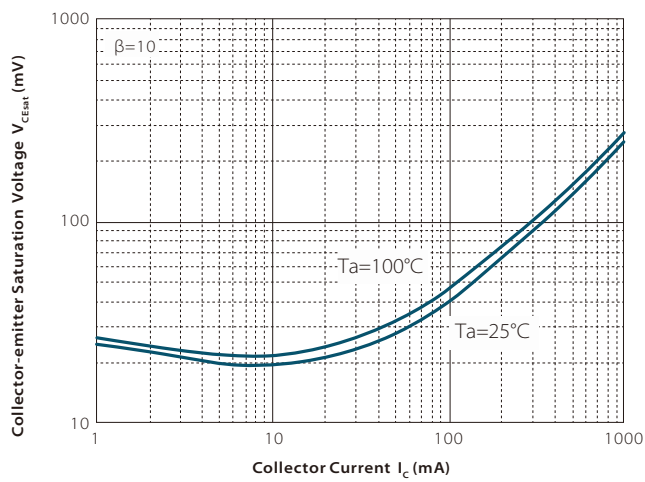

$V_{BE\text{sat}}$ — I_C

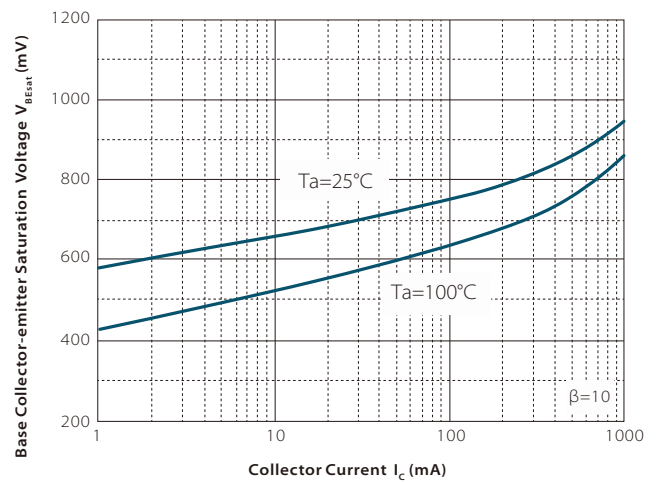

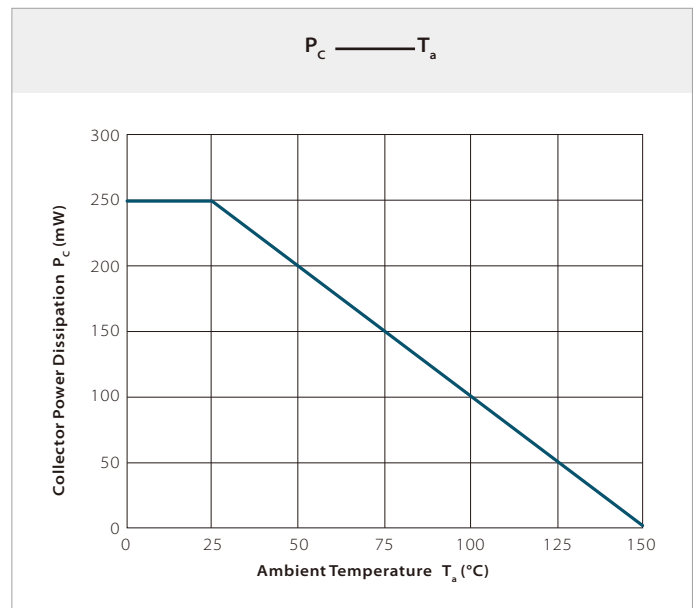
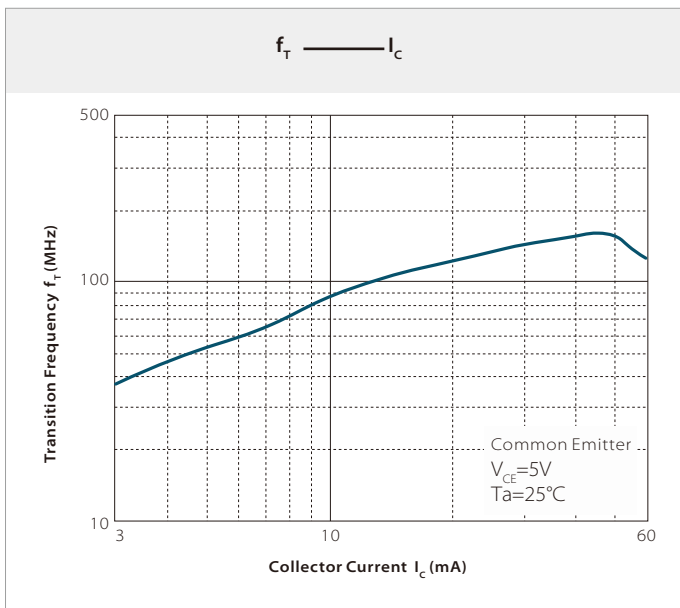
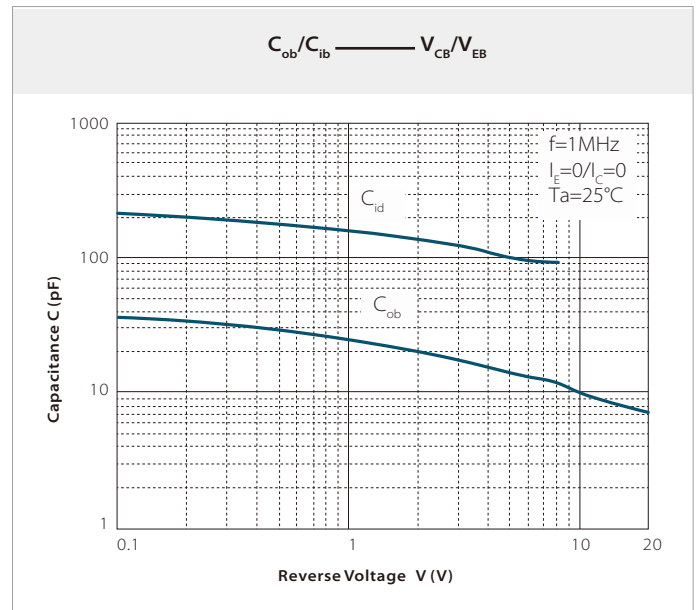
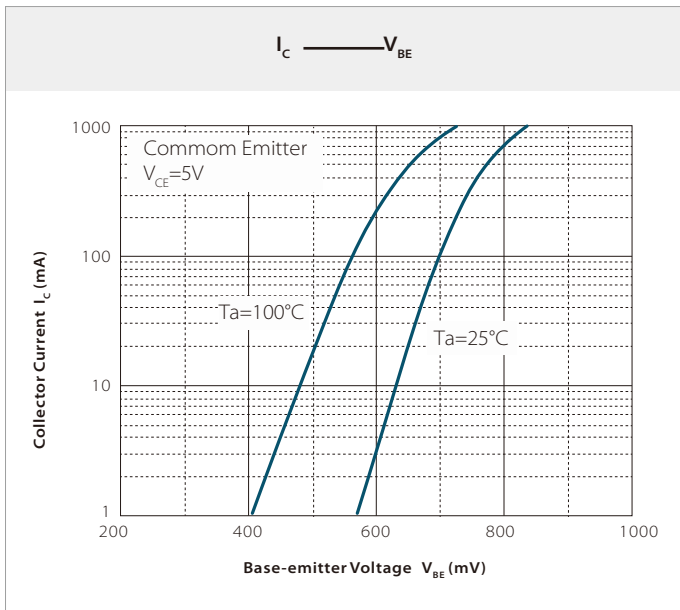

SOT-23 PACKAGE INFORMATION

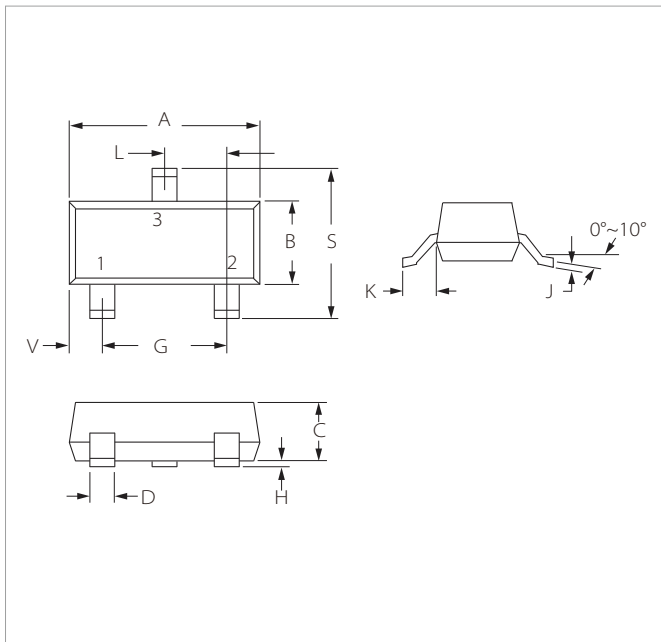

Ref.	Millimeters		Inches	
	Min.	Max.	Min.	Max.
A	2.80	3.04	0.110	0.120
B	1.20	1.40	0.047	0.055
C	0.89	1.11	0.035	0.044
D	0.37	0.50	0.015	0.020
G	1.78	2.04	0.070	0.081
H	0.01	0.100	0.001	0.004
J	0.085	0.180	0.003	0.007
K	0.35	0.69	0.014	0.029
L	0.89	1.02	0.035	0.040
S	2.10	2.64	0.083	0.104
V	0.45	0.60	0.018	0.024

RECOMMENDED PAD LAYOUT DIMENSIONS

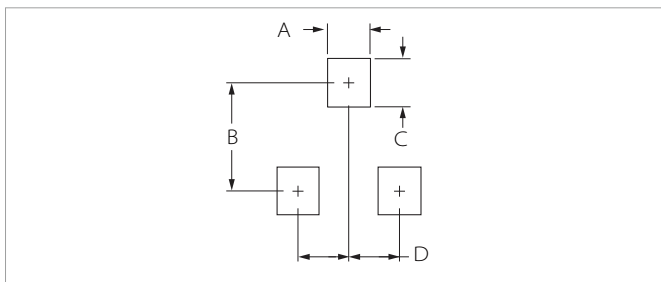

Ref.	Millimeters		Inches	
	Min.	Max.	Min.	Max.
A	0.71	0.97	0.028	0.038
B	1.88	2.13	0.074	0.084
C	0.71	0.97	0.028	0.038
D	0.81	1.07	0.032	0.042

ORDERING INFORMATION

Part Number	Component Package	QTY/Reel	Reel Size
FMMT491	SOT-23	3000PCS	7"

To find your local partner within Semiwell's website : www.semiwell.com.cn

©2023 Semiwell Microelectronics Co.,Ltd.

The content of this document has been carefully checked and understood. However, neither Semiwell nor its subsidiaries assume any liability whatsoever for any errors or inaccuracies of this document and the consequences thereof. Published specifications are subject to change without notice. Product suitability for any area of application must ultimately be determined by the customer. In all cases, products must never be operated outside their published specifications. Semiwell does not guarantee the availability of all published products. This disclaimer shall be governed by substantive Chinese law and resulting disputes shall be settled by the courts at the place of business of Semiwell. Latest publications and a complete disclaimer can be downloaded from the Semiwell website. All trademarks recognized.