

FEATURES

- | 100W Peak Pulse Power per Line (tp=8/20μs)
- | Protects One bidirectional I/O line
- | Working voltages : 5 V
- | Low leakage current
- | Low clamping voltage

APPLICATIONS

- | Cell Phone Handsets and Accessories
- | Microprocessor based equipment
- | Personal Digital Assistants (PDA' s)
- | Notebooks, Desktops, and Servers
- | Portable Instrumentation
- | Peripherals
- | Pagers

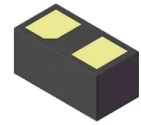

DFN0603

D5

Marking

IEC COMPATIBILITY

- | IEC61000-4-2 (ESD) ±15kV (air), ±8kV (contact)
- | IEC61000-4-4 (EFT) 40A (5/50ns)

APPROVALS

RoHS	Compliance with 2011/65/EU
HF	Compliance with IEC61249-2-21:2003

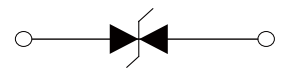

Schematic Symbol

THERMAL CONSIDERATIONS

Symbol	Parameter	Value	Unit
P_{PP}	Peak Pulse Power (tp=8/20μs waveform)	100	Watts
T_J	Operating Temperature Range	-55 to +150	°C
T_{STG}	Storage Temperature Range	-55 to +150	°C

ELECTRICAL CHARACTERISTICS

Symbol	Parameter	Condition	Min.	Typ.	Max.	Unit
V_{RWM}	Reverse Stand-off Voltage				5	V
V_{BR}	Reverse Breakdown Voltage	$I_T=1mA$	5.6			V
I_R	Reverse Leakage Current	$V_{RWM}=5V$			0.5	μA
V_C	Clamping Voltage (Tp=8/20us)	$I_{PP}=1A, tp=8/20us$			9.8	V
V_C	Clamping Voltage (Tp=8/20us)	$I_{PP}=5.5A, tp=8/20us$			12.5	V
I_{PP}	Peak Pulse Current (Tp=8/20us)	tp=8/20us			5.5	A
C_J	Off State Junction Capacitance	$V_R=0V, f=1MHz$		15		pF

CHARACTERISTIC CURVES

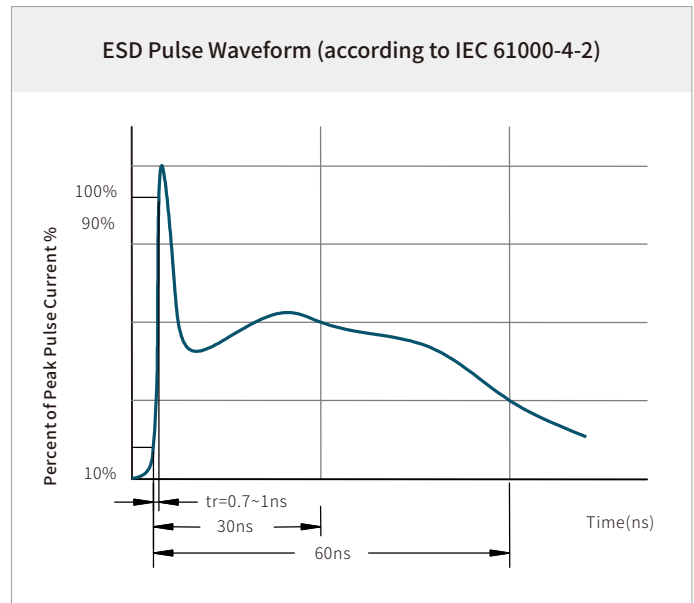
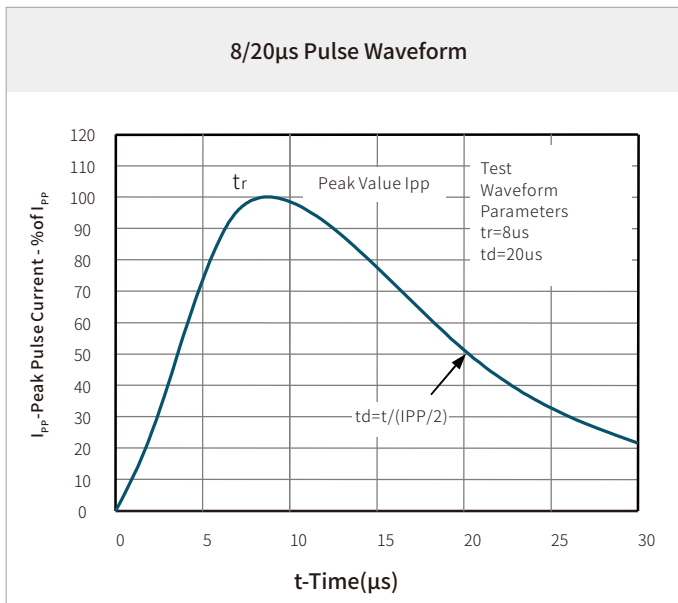

SOLDERING PARAMETERS

Reflow Condition		Lead-free assembly
Pre Heat	Temperature Max ($T_{s(min)}$)	150°C
	Temperature Max ($T_{s(max)}$)	200°C
	Time (min to max) (t_s)	60 – 180 secs
Average ramp up rate (Liquidus Temp (T_L) to peak)		3°C/second max
$T_{s(max)}$ to T_L - Ramp-up Rate		3°C/second max
Reflow	Temperature (T_L) (Liquidus)	217°C
	Time (min to max) (t_L)	60 – 150 seconds
Peak Temperature (T_p)		260°C
Time within 5°C of actual peak Temperature (t_p)		20 – 40 seconds
Ramp-down Rate		6°C/second max
Time 25°C to peak Temperature (T_p)		8 minutes max.
Do not exceed		260°C

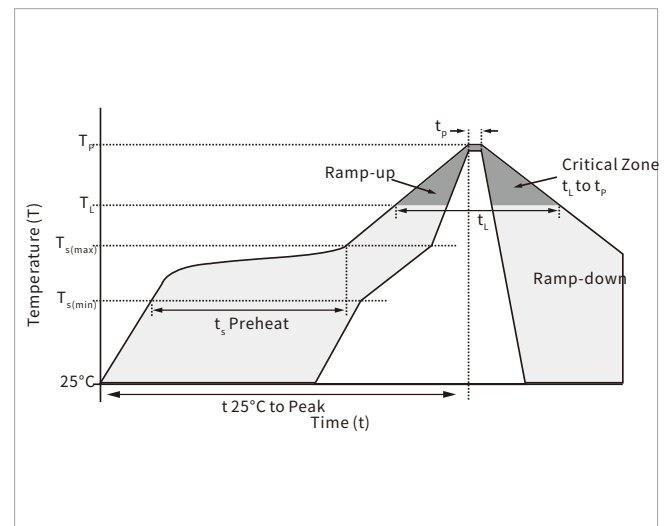

DFN0603 PACKAGE INFORMATION

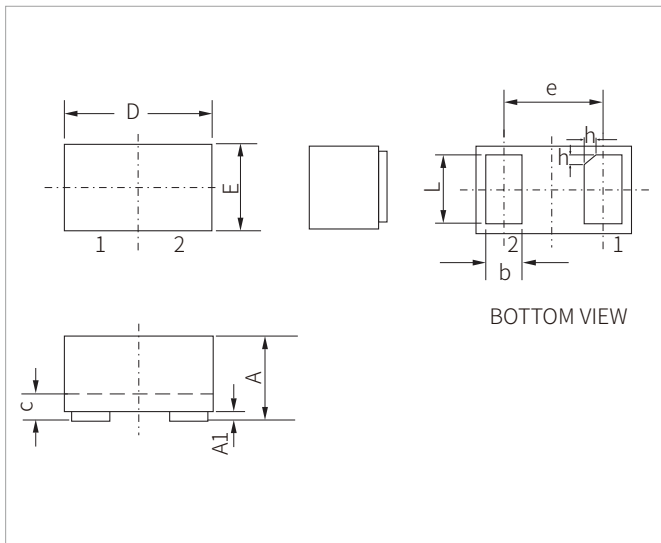

Ref.	Millimeters		Inches	
	Min.	Max.	Min.	Max.
A	0.28	0.34	0.011	0.014
A1	0	0.05	0	0.002
b	0.13	0.24	0.005	0.009
c	0.05	0.15	0.002	0.006
D	0.55	0.65	0.022	0.026
e	0.35BSC		0.014BSC	
E	0.25	0.35	0.010	0.014
L	0.20	0.30	0.008	0.012
h	0	0.10	0	0.004

RECOMMENDED PAD LAYOUT DIMENSIONS

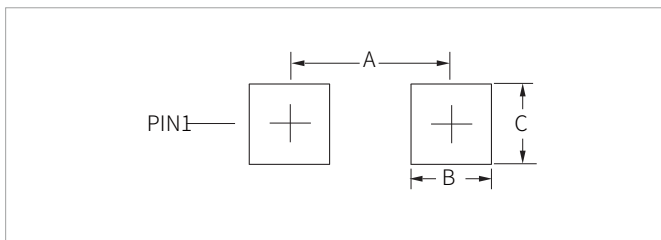

Ref.	Millimeters	Inches
A	0.38	0.015
B	0.23	0.009
C	0.30	0.012

ORDERING INFORMATION

Part Number	Component Package	QTY/Reel	Reel Size
ESD5451XZ	DFN0603	15000PCS	7"

To find your local partner within Semiwell' s website : www.semiwell.com.cn

© 2023 Semiwell Microelectronics Co.,Ltd.

The content of this document has been carefully checked and understood. However, neither Semiwell nor its subsidiaries assume any liability whatsoever for any errors or inaccuracies of this document and the consequences thereof. Published specifications are subject to change without notice. Product suitability for any area of application must ultimately be determined by the customer. In all cases, products must never be operated outside their published specifications. Semiwell does not guarantee the availability of all published products. This disclaimer shall be governed by substantive Chinese law and resulting disputes shall be settled by the courts at the place of business of Semiwell. Latest publications and a complete disclaimer can be downloaded from the Semiwell website. All trademarks recognized.