

FEATURES

- | Low Zener Impedance

- | Power Dissipation of 300mW

- | High Stability and High Reliability

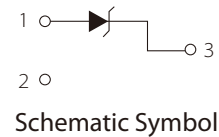
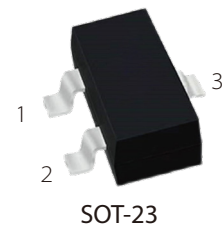

MECHANICAL DATA

- | SOT-23 Small Outline Plastic Package

- | Epoxy UL: 94V-0

- | Mounting Position: Any

APPROVALS

RoHS	Compliance with 2011/65/EU
HF	Compliance with IEC61249-2-21:2003

MAXIMUM RATINGS (T_A=25°C)

Parameter	Symbo	Value	Unit
Power Dissipation	P _D	300	mW
Maximum forward voltage at I _F =10mA	V _F	0.9	V
Storage temperature range	T _S	-65 to +150	°C
Thermal resistance junction to ambient air Warmewider stand Sperrschicht -umgebende Luft	R _{thA}	417	K/W

ELECTRICAL CHARACTERISTICS

Part Number	Device Marking Code	Zener Voltage Range				Maximum Zener Impedance			Maximum Reverse Current		Typical temperature coefficient @ I_{ZT} mV/°C	
		$V_Z @ I_{ZT}$			I_{ZT}	$Z_{ZT} @ I_{ZT}$	$Z_{ZK} @ I_{ZK}$		I_R	V_R		
		Nom(V)	Min(V)	Max(V)	(mA)	(Ω)	(mA)	(μ A)	(V)	Min	Max	
BZX84B2V4	2Z11	2.4	2.35	2.45	5	100	600	1.0	50	1.0	-3.5	0
BZX84B2V7	2Z12	2.7	2.65	2.75	5	100	600	1.0	20	1.0	-3.5	0
BZX84B3V0	2Z13	3.0	2.94	3.06	5	95	600	1.0	10	1.0	-3.5	0
BZX84B3V3	2Z14	3.3	3.23	3.37	5	95	600	1.0	5	1.0	-3.5	0
BZX84B3V6	2Z15	3.6	3.53	3.67	5	90	600	1.0	5	1.0	-3.5	0
BZX84B3V9	2Z16	3.9	3.82	3.98	5	90	600	1.0	3	1.0	-3.5	0
BZX84B4V3	2Z17	4.3	4.21	4.39	5	90	600	1.0	3	1.0	-3.5	0
BZX84B4V7	2Z1	4.7	4.61	4.79	5	80	500	1.0	3	2.0	-3.5	0.2
BZX84B5V1	2Z2	5.1	5.00	5.20	5	60	480	1.0	2	2.0	-2.7	1.2
BZX84B5V6	2Z3	5.6	5.49	5.71	5	40	400	1.0	1	2.0	-2.0	2.5
BZX84B6V2	2Z4	6.2	6.08	6.32	5	10	150	1.0	3	4.0	0.4	3.7
BZX84B6V8	2Z5	6.8	6.66	6.94	5	15	80	1.0	2	4.0	1.2	4.5
BZX84B7V5	2Z6	7.5	7.35	7.65	5	15	80	1.0	1	5.0	2.5	5.3
BZX84B8V2	2Z7	8.2	8.04	8.36	5	15	80	1.0	0.7	5.0	3.2	6.2
BZX84B9V1	2Z8	9.1	8.92	9.28	5	15	100	1.0	0.5	6.0	3.8	7.0
BZX84B10	2Z9	10	9.80	10.20	5	20	150	1.0	0.2	7.0	4.5	8.0
BZX84B11	2Y1	11	10.78	11.22	5	20	150	1.0	0.1	8.0	5.4	9.0
BZX84B12	2Y2	12	11.76	12.24	5	25	150	1.0	0.1	8.0	6.0	10.0
BZX84B13	2Y3	13	12.74	13.26	5	30	170	1.0	0.1	8.0	7.0	11.0
BZX84B15	2Y4	15	14.70	15.60	5	30	200	1.0	0.1	10.5	9.2	13.0
BZX84B16	2Y5	16	15.68	16.32	5	40	200	1.0	0.1	11.2	10.4	14.0
BZX84B18	2Y6	18	17.64	18.36	5	45	225	1.0	0.1	12.6	12.4	16.0
BZX84B20	2Y7	20	19.60	20.40	5	55	225	1.0	0.1	14.0	14.4	18.0
BZX84B22	2Y8	22	21.56	22.44	5	55	250	1.0	0.1	15.4	16.4	20.0
BZX84B24	2Y9	24	23.52	24.48	5	70	250	1.0	0.1	16.8	18.4	22.0
BZX84B27	2Y10	27	26.46	27.54	2	80	300	0.5	0.1	18.9	21.4	25.3
BZX84B30	2Y11	30	29.40	30.60	2	80	300	0.5	0.1	21.0	24.4	29.4
BZX84B33	2Y12	33	32.34	33.66	2	80	325	0.5	0.1	23.1	27.1	33.4
BZX84B36	2Y13	36	35.28	36.72	2	90	350	0.5	0.1	25.2	30.4	37.4
BZX84B39	2Y14	39	38.22	39.78	2	130	350	0.5	0.1	27.3	33.4	41.2

CHARACTERISTIC CURVES

Zener Characteristics (V_z 5.1V to 20 V)

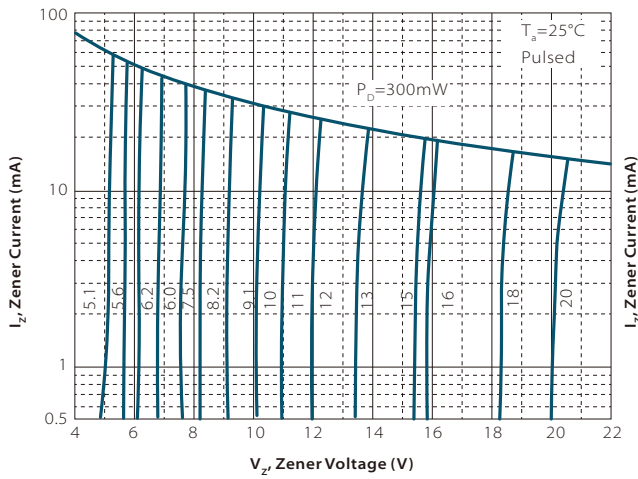

Temperature Coefficients

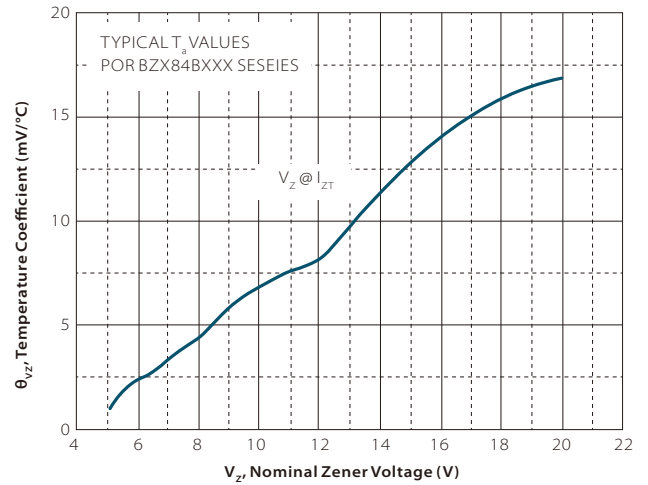

Typical Leakage Current

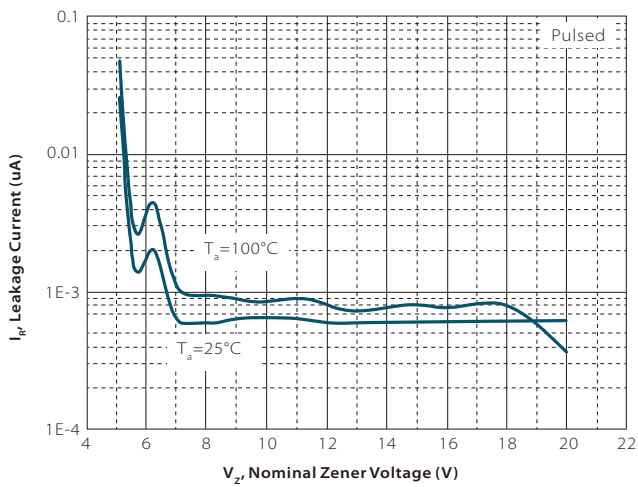

Typical Capacitance

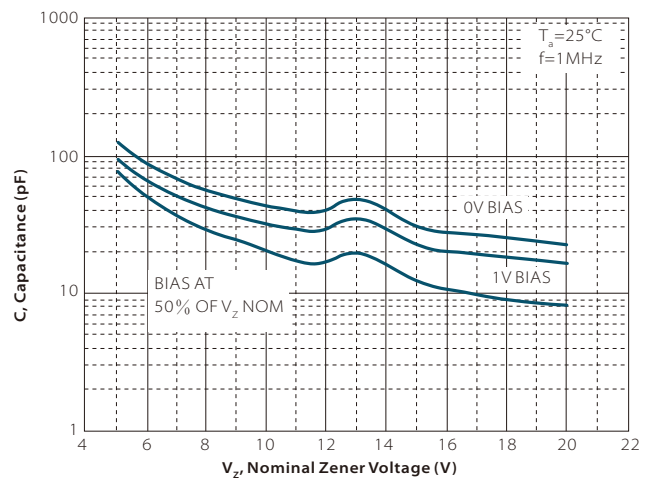

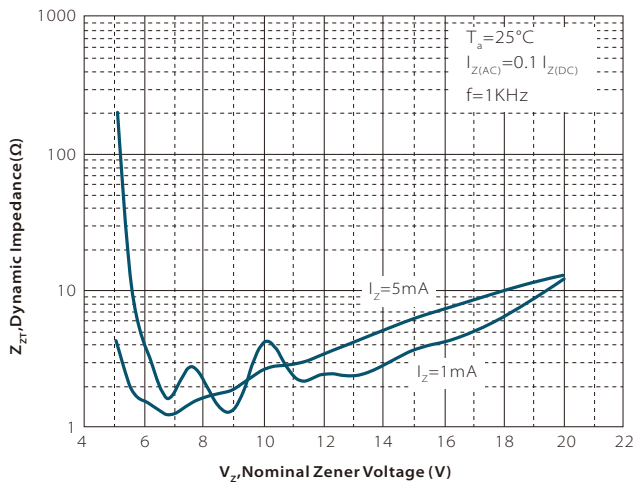
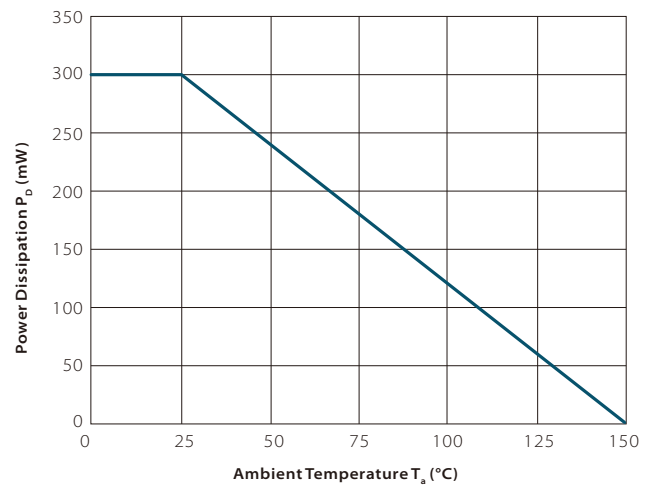
Effect of Zener Voltage on Zener Impedance

Power Derating Curve

SOLDERING PARAMETERS

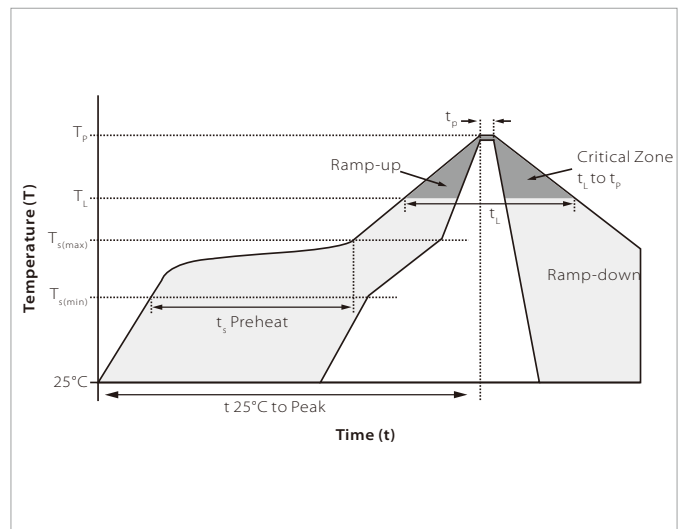
Reflow Condition		Lead-free assembly
Pre Heat	Temperature Max ($T_{s(\min)}$)	150 $^\circ\text{C}$
	Temperature Max ($T_{s(\max)}$)	200 $^\circ\text{C}$
	Time (min to max) (t_s)	60 – 180 secs
Average ramp up rate (Liquidus Temp (T_L) to peak)		3 $^\circ\text{C}/\text{second}$ max
$T_{s(\max)}$ to T_L - Ramp-up Rate		3 $^\circ\text{C}/\text{second}$ max
Reflow	Temperature (T_L) (Liquidus)	217 $^\circ\text{C}$
	Time (min to max) (t_L)	60 – 150 seconds
Peak Temperature (T_p)		260 $^\circ\text{C}$
Time within 5 $^\circ\text{C}$ of actual peak Temperature (t_p)		20 – 40 seconds
Ramp-down Rate		6 $^\circ\text{C}/\text{second}$ max
Time 25 $^\circ\text{C}$ to peak Temperature (T_p)		8 minutes max.
Do not exceed		260 $^\circ\text{C}$

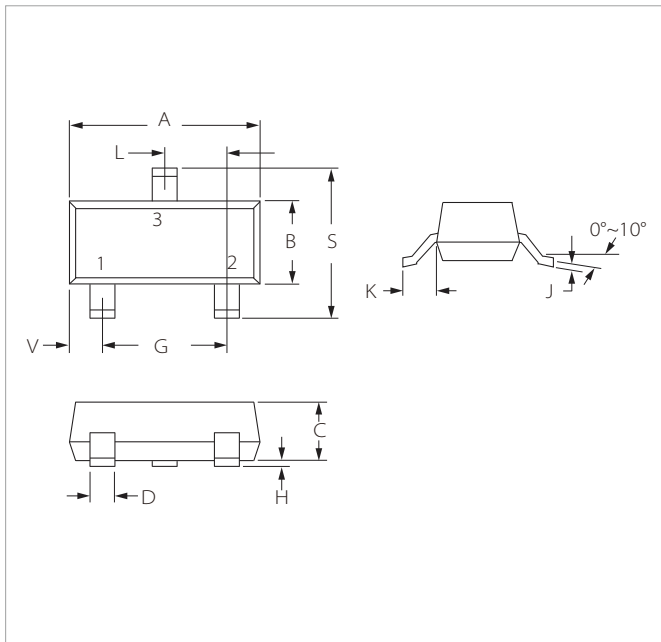

SOT-23 PACKAGE INFORMATION



Ref.	Millimeters		Inches	
	Min.	Max.	Min.	Max.
A	2.80	3.04	0.110	0.120
B	1.20	1.40	0.047	0.055
C	0.89	1.11	0.035	0.044
D	0.37	0.50	0.015	0.020
G	1.78	2.04	0.070	0.081
H	0.01	0.100	0.001	0.004
J	0.085	0.180	0.003	0.007
K	0.35	0.69	0.014	0.029
L	0.89	1.02	0.035	0.040
S	2.10	2.64	0.083	0.104
V	0.45	0.60	0.018	0.024

RECOMMENDED PAD LAYOUT DIMENSIONS

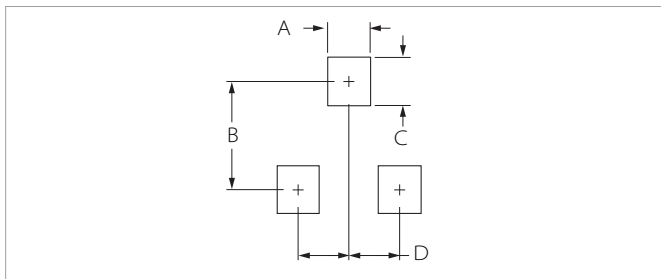

Ref.	Millimeters		Inches	
	Min.	Max.	Min.	Max.
A	0.71	0.97	0.028	0.038
B	1.88	2.13	0.074	0.084
C	0.71	0.97	0.028	0.038
D	0.81	1.07	0.032	0.042

ORDERING INFORMATION

Part Number	Component Package	QTY/Reel	Reel Size
BZX84B Series	SOT-23	3000PCS	7"

To find your local partner within Semiwell's website : www.semiwell.com.cn

©2023 Semiwell Microelectronics Co.,Ltd.

The content of this document has been carefully checked and understood. However, neither Semiwell nor its subsidiaries assume any liability whatsoever for any errors or inaccuracies of this document and the consequences thereof. Published specifications are subject to change without notice. Product suitability for any area of application must ultimately be determined by the customer. In all cases, products must never be operated outside their published specifications. Semiwell does not guarantee the availability of all published products. This disclaimer shall be governed by substantive Chinese law and resulting disputes shall be settled by the courts at the place of business of Semiwell. Latest publications and a complete disclaimer can be downloaded from the Semiwell website. All trademarks recognized.