

FEATURES

- | High surge current handling capability
- | High energy absorption capability
- | Wide operating voltages ranging from 10Vrms to 1000Vrms
- | Fast response time of less than 25ns, instantly clamping the transient over voltage
- | Low clamping voltages, providing better surge protection
- | Low capacitance values, providing digital switching circuitry protection
- | High insulation resistance, preventing electric arcing to the adjacent devices or circuits



20D

APPLICATIONS

- | Surge protection of consumer equipment
- | Surge protection of communication, measuring and controller instrument
- | Surge protection in electronic home appliances, gas and petroleum appliances
- | Relay and electromagnetic valve surge absorption
- | Transistor, Diode, IC, Thyristor or Triac semiconductor protection

APPROVALS

RoHS	Compliance with 2011/65/EU
HF	Compliance with IEC61249-2-21:2003

GENERAL CHARACTERISTICS DEFINITION

- | Operating Temperature Range : -40°C ~ +85°C
- | Storage Temperature Range : -40°C ~ +125°C
- | Working Surface Temperature : +115°C
- | Insulation Resistance : >100MΩ

MATERIAL

- | Coating: Epoxy Resin
- | Lead Wire: The Copper Wire
- | Electrode: Silver Solder
- | Disk: Zinc Oxide

ELECTRICAL CHARACTERISTICS

Symbol		Mximum Allowable Voltage		Varistor Voltage @1mA	Mximum Clamping Voltage		Withstanding Surge Current (8/20μs)		Maximum Energy (10/1000μs)		Rated Power	Typical Capacitance (Reference)
Standard	High Surge	V _{ac} (V)	V _{dc} (V)	(V)	V _c (V)	I _p (A)	I(A) Standard	I(A) High Surge	(J) Standard	(J) High Surge	(W)	@1KHz (pF)
20D180L	20D180LJ	10	14	18(15-21)	38	20	2000	3000	6.1	13.0	0.2	19000
20D220K	20D220KJ	14	18	22(20-24)	43	20	2000	3000	7.4	16.0	0.2	15000
20D270K	20D270KJ	17	22	27(24-30)	53	20	2000	3000	9.1	19.0	0.2	12000
20D330K	20D330KJ	20	26	33(30-36)	65	20	2000	3000	11.2	24.0	0.2	10000
20D390K	20D390KJ	25	31	39(35-43)	77	20	2000	3000	13.2	28.0	0.2	8500
20D470K	20D470KJ	30	38	47(42-52)	93	20	2000	3000	16.8	34.0	0.2	7400
20D560K	20D560KJ	35	45	56(50-62)	110	20	2000	3000	19.6	41.0	0.2	6500
20D680K	20D680KJ	40	56	68(61-75)	135	20	2000	3000	23.8	49.0	0.2	5800
20D820K	20D820KJ	50	65	82(74-90)	135	100	6500	10000	37.8	56.0	1.0	4900
20D101K	20D101KJ	60	85	100(90-110)	165	100	6500	10000	42.0	70.0	1.0	4000
20D121K	20D121KJ	75	100	120(108-132)	200	100	6500	10000	56.0	85.0	1.0	3300
20D151K	20D151KJ	95	125	150(135-165)	250	100	6500	10000	70.0	106	1.0	2700
20D181K	20D181KJ	115	150	180(162-198)	300	100	6500	10000	84.0	130	1.0	2200
20D201K	20D201KJ	130	170	200(185-225)	330	100	6500	10000	98.0	140	1.0	2000
20D221K	20D221KJ	140	180	220(198-242)	360	100	6500	10000	105	155	1.0	1800
20D241K	20D241KJ	150	200	240(216-264)	395	100	6500	10000	112	168	1.0	1650
20D271K	20D271KJ	175	225	270(243-297)	455	100	6500	10000	126	190	1.0	1500
20D301K	20D301KJ	190	250	300(270-330)	505	100	6500	10000	133	210	1.0	1300
20D331K	20D331KJ	210	275	330(297-363)	550	100	6500	10000	140	228	1.0	1200
20D361K	20D361KJ	230	300	360(324-396)	595	100	6500	10000	168	255	1.0	1100
20D391K	20D391KJ	250	320	390(351-429)	650	100	6500	10000	182	275	1.0	1000
20D431K	20D431KJ	275	350	430(387-473)	710	100	6500	10000	196	305	1.0	930
20D471K	20D471KJ	300	385	470(423-517)	775	100	6500	10000	202	350	1.0	850
20D511K	20D511KJ	320	415	510(459-561)	845	100	6500	10000	207	360	1.0	780
20D561K	20D561KJ	350	460	560(504-616)	920	100	6500	10000	210	366	1.0	715
20D621K	20D621KJ	385	505	620(558-682)	1025	100	6500	10000	224	372	1.0	650
20D681K	20D681KJ	420	560	680(612-748)	1120	100	6500	10000	224	382	1.0	600
20D751K	20D751KJ	460	615	750(675-825)	1240	100	6500	10000	230	410	1.0	530

Symbol		Mximum Allowable Voltage		Varistor Voltage @1mA	Mximum Clamping Voltage		Withstanding Surge Current (8/20μs)		Maximum Energy (10/1000μs)		Rated Power	Typical Capacitance (Reference)
Standard	High Surge	V _{AC} (V)	V _{DC} (V)	(V)	V _c (V)	I _p (A)	I(A) Standard	I(A) High Surge	(J) Standard	(J) High Surge	(W)	@1KHz (pF)
20D781K	20D781KJ	485	640	780(702-858)	1290	100	6500	10000	240	421	1.0	510
20D821K	20D821KJ	510	670	820(738-902)	1355	100	6500	10000	250	460	1.0	500
20D911K	20D911KJ	550	745	910(819-1001)	1500	100	6500	10000	260	510	1.0	440
20D102K	20D102KJ	625	825	1000(900-1100)	1650	100	6500	10000	270	560	1.0	400
20D112K	20D112KJ	680	895	1100(990-1210)	1815	100	6500	10000	280	620	1.0	360
20D152K	20D152KJ	900	1200	1500(1350-1650)	2475	100	6500	10000	420	780	1.0	260
20D182K	20D182KJ	1000	1465	1800(1620-1980)	2970	100	6500	10000	560	860	1.0	220

CHARACTERISTIC CURVES

Items	Test condition/Description					
Varistor Voltage	The voltage across the varistor measured at 1mA DC,can be called Vb					
Maximum Allowable Voltage	Maximum continuous sine wave(RMS) or DC voltage which may be applied					
Maximum Clamping Voltage	Peak voltage across the varistor with a specified peak impulse current of 8/20μs waveform					
Rated Power	The maximum average power that can be applied within the specified ambient temperature					
Withstanding Surge Current	The maximum current within the varistor voltage change of less than ±10% when one impulse current(8/20μs)applied					
Energy	The max.energy absorbed with a varistor voltage change of less than ± 10% when one impulse (10/1000μs) is applied					
Varistor Voltage Temperature Coefficient	$\left \frac{Vb@85^{\circ}C - Vb@25^{\circ}C}{Vb@25^{\circ}C} \times \frac{1}{60} \times 100\% (\%/^{\circ}C) \right \leq 0.05\% / ^{\circ}C$ $\left \frac{Vb@-40^{\circ}C - Vb@25^{\circ}C}{Vb@25^{\circ}C} \times \frac{1}{65} \times 100\% (\%/^{\circ}C) \right \leq 0.05\% / ^{\circ}C$					
Surge Life	The max.current with a varistor voltage change of less than ±10% when 10,000 times impulse current (8/20μs) are applied at intervals of 20 seconds at room temperature <table border="1" style="margin-left: auto; margin-right: auto;"> <tr> <td rowspan="2">20D Series</td> <td>180L to 680K</td> <td>100A(8/20μs)</td> </tr> <tr> <td>820K to 182K</td> <td>200A(8/20μs)</td> </tr> </table>	20D Series	180L to 680K	100A(8/20μs)	820K to 182K	200A(8/20μs)
20D Series	180L to 680K		100A(8/20μs)			
	820K to 182K	200A(8/20μs)				

CHARACTERISTIC CURVES

Items	Test condition/Description	Specifications															
High Temperature Storage	Ambient Temp:125±2°C Duration:1000 hrs	$ \Delta V_{1_{mA}}/V_{1_{mA}} \leq 5\%$															
Low Temperature Storage	Ambient Temp:-40±2°C Duration:1000 hrs	$ \Delta V_{1_{mA}}/V_{1_{mA}} \leq 5\%$															
Humidity	Ambient Temp:40±2°C,90~95% R.H. Duration:1000 hrs	$ \Delta V_{1_{mA}}/V_{1_{mA}} \leq 5\%$															
Temperature Cycle	The conditions shown below shall be repeated 5 cycles <table border="1" style="margin-left: auto; margin-right: auto;"> <thead> <tr> <th>Step</th> <th>Temperature(°C)</th> <th>Period(minutes)</th> </tr> </thead> <tbody> <tr> <td>1</td> <td>-40±3</td> <td>30±3</td> </tr> <tr> <td>2</td> <td>Room temperature</td> <td>15±3</td> </tr> <tr> <td>3</td> <td>125±3</td> <td>30±3</td> </tr> <tr> <td>4</td> <td>Room temperature</td> <td>15±3</td> </tr> </tbody> </table>	Step	Temperature(°C)	Period(minutes)	1	-40±3	30±3	2	Room temperature	15±3	3	125±3	30±3	4	Room temperature	15±3	No visible damage $ \Delta V_{1_{mA}}/V_{1_{mA}} \leq 5\%$
Step	Temperature(°C)	Period(minutes)															
1	-40±3	30±3															
2	Room temperature	15±3															
3	125±3	30±3															
4	Room temperature	15±3															
High Temperature Load	Ambient Temp:85±2°C ,Duration:1000 hrs Load:Max.Allowable Voltage in AC eara	$ \Delta V_{1_{mA}}/V_{1_{mA}} \leq 10\%$															
Damp Heat Load	Ambient Temp:40±2°C ,90~95% R.H. Duration:1000 hrs Load:Max.Allowable Voltage	No visible damage $ \Delta V_{1_{mA}}/V_{1_{mA}} \leq 10\%$															
Voltage Proof	Metal balls method,2500Vac 1 min	No visible damage															

WAVE SOLDERING

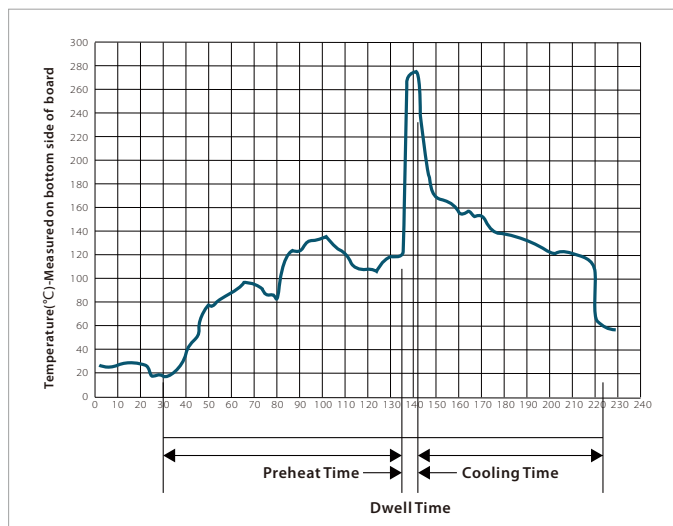

Wave Parameter		Lead-free assembly
Pre Heat	Temperature Min	100°C
	Temperature Max	150°C
	Time(min to max)	60 – 180 secs
Solder pot Temperature		280°C Max
Solder Dwell Time		2-5 seconds

PACKAGE INFORMATION

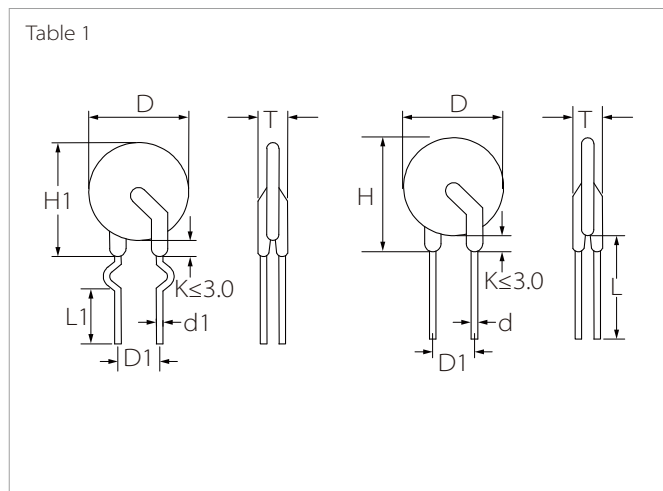

Symbol	Dimension(mm)
H(max)	28.0
H1(max)	28.0
L(min)	20.0
L1(min)	15.0
D(max)	22.0
D1(±0.8)	10.0
T(max)	Table2
d(±0.05)	1.0
d1(±0.4)	1.4

Table 2		Tmax(mm)					
20D180L	4.0	20D101K	4.3	20D331K	4.8	20D751K	6.5
20D220K	4.0	20D121K	4.5	20D361K	5.0	20D781K	6.8
20D270K	4.0	20D151K	4.8	20D391K	5.1	20D821K	7.2
20D330K	4.2	20D181K	4.1	20D431K	5.3	20D911K	7.6
20D390K	4.5	20D201K	4.1	20D471K	5.6	20D102K	7.8
20D470K	4.5	20D221K	4.2	20D511K	5.8	20D112K	8.5
20D560K	4.1	20D241K	4.3	20D561K	6.2	20D152K	11.0
20D680K	4.1	20D271K	4.5	20D621K	6.4	20D182K	12.5
20D820K	4.1	20D301K	4.7	20D681K	6.4		

ORDERING INFORMATION

Part Number	Component Package	Package
20D SERIES	20D	250PCS

To find your local partner within Semiwell's website : www.semiwell.com.cn

© 2023 Semiwell Microelectronics Co.,Ltd.

The content of this document has been carefully checked and understood. However, neither Semiwell nor its subsidiaries assume any liability whatsoever for any errors or inaccuracies of this document and the consequences thereof. Published specifications are subject to change without notice. Product suitability for any area of application must ultimately be determined by the customer. In all cases, products must never be operated outside their published specifications. Semiwell does not guarantee the availability of all published products. This disclaimer shall be governed by substantive Chinese law and resulting disputes shall be settled by the courts at the place of business of Semiwell. Latest publications and a complete disclaimer can be downloaded from the Semiwell website. All trademarks recognized.