

FEATURES

- | Low Leakage Current

- | High Switching Speed

- | Low-leakage Current Applications

- | in Surface Mounted Circuits

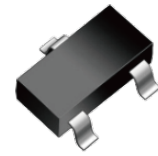

SOT-23

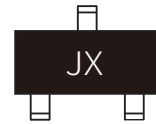

Marking

MECHANICAL DATA

- | SOT-23 Small Outline Plastic Package

- | Epoxy UL: 94V-0

- | Mounting Position: Any

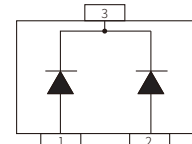

Schematic Symbol

APPROVALS

RoHS	Compliance with 2011/65/EU
HF	Compliance with IEC61249-2-21:2003

MAXIMUM RATINGS ($T_A=25^{\circ}\text{C}$)

Parameter	Symbol	Value	Unit
DC Blocking Voltage	V_R	75	V
Repetitive Peak Reverse Voltage	V_{RRM}	85	V
Power Dissipation	P_D	250	mW
Forward Current(single diode)	I_F	215	mA
Forward Current(double diode)		125	
Non-Repetitive Peak Forward Surge Current@ $t=8.3\text{ms}$	I_{FSM}	1	A
Repetitive Peak Forward Current	I_{FRM}	500	mA
Operation Junction and Storage Temperature Range	$T_J T_{stg}$	-55 to +150	$^{\circ}\text{C}$
Thermal Resistance from Junction to Ambient	$R_{\theta JA}$	500	$^{\circ}\text{C}/\text{W}$

ELECTRICAL CHARACTERISTICS($T_A=25^{\circ}\text{C}$)

Parameter	Test Condition	Symbol	Min.	Typ.	Max.	Unit
Reverse Voltage	$I_B=100\mu\text{A}$	V_{RB}	75			V
Reverse Leakage Current	$V_R=75\text{V}$	I_R			5	nA
Forward Voltage	$I_F=1\text{mA}$	V_F			0.90	V
	$I_F=10\text{mA}$				1.00	
	$I_F=50\text{mA}$				1.10	
	$I_F=150\text{mA}$				1.25	
Reverse Recovery Time	$I_F=I_R=10\text{mA}, R_t=100\Omega$ $I_{RR}=0.1 \times I_R$	T_{RR}			3	μS
Capacitance	$V_R=0\text{V}, f=1\text{MHz}$	C_T		2.0		pF

CHARACTERISTIC CURVES

Fig 1. Forward Characteristics

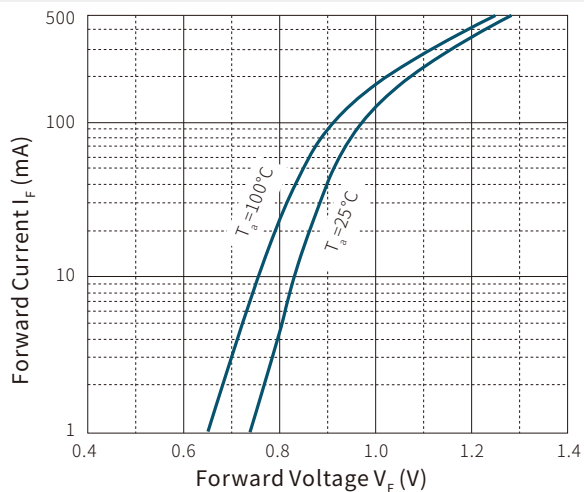

Fig 2. Reverse Characteristics

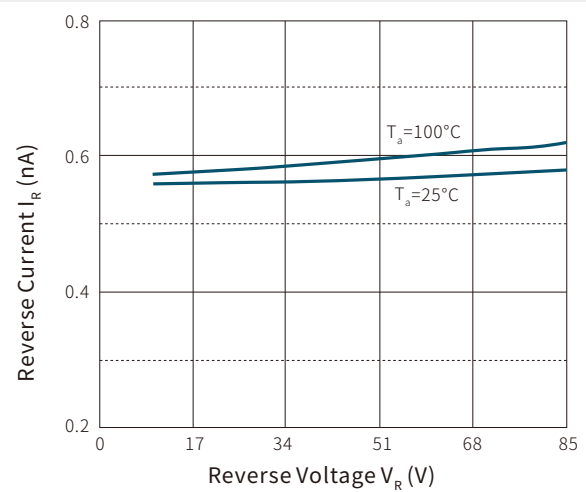
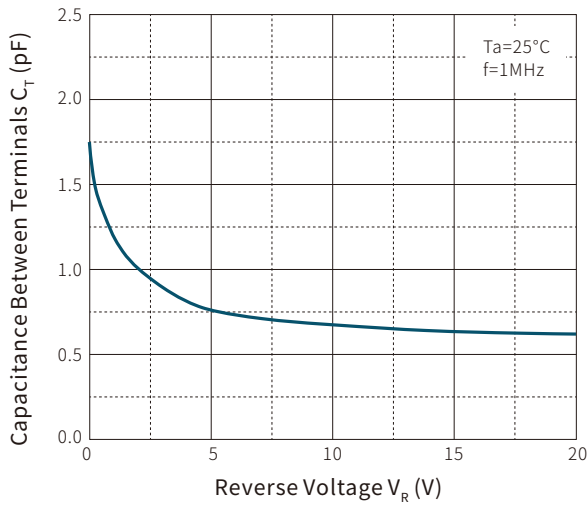
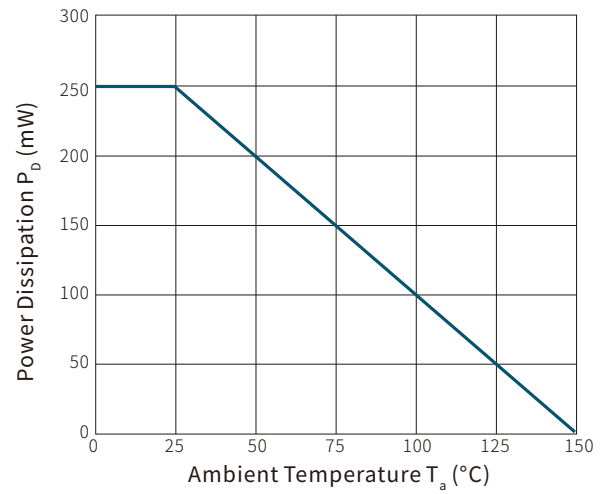
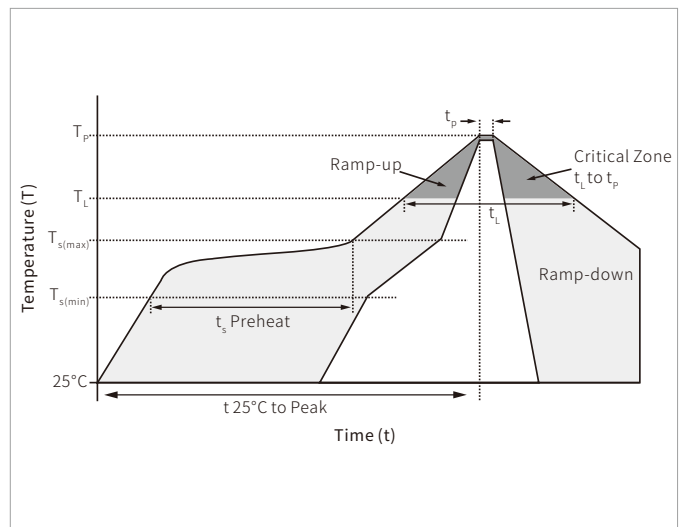

Fig 3. Capacitance Characteristics

Fig 4. Power Derating Curve

SOLDERING PARAMETERS

Reflow Condition		Lead-free assembly
Pre Heat	Temperature Max ($T_{s(\min)}$)	150 $^\circ\text{C}$
	Temperature Max ($T_{s(\max)}$)	200 $^\circ\text{C}$
	Time (min to max) (t_s)	60 – 180 secs
Average ramp up rate (Liquidus Temp (T_L) to peak)		3 $^\circ\text{C}/\text{second}$ max
$T_{s(\max)}$ to T_L - Ramp-up Rate		3 $^\circ\text{C}/\text{second}$ max
Reflow	Temperature (T_L) (Liquidus)	217 $^\circ\text{C}$
	Time (min to max) (t_L)	60 – 150 seconds
Peak Temperature (T_p)		260 $^\circ\text{C}$
Time within 5 $^\circ\text{C}$ of actual peak Temperature (t_p)		20 – 40 seconds
Ramp-down Rate		6 $^\circ\text{C}/\text{second}$ max
Time 25 $^\circ\text{C}$ to peak Temperature (T_p)		8 minutes max.
Do not exceed		260 $^\circ\text{C}$

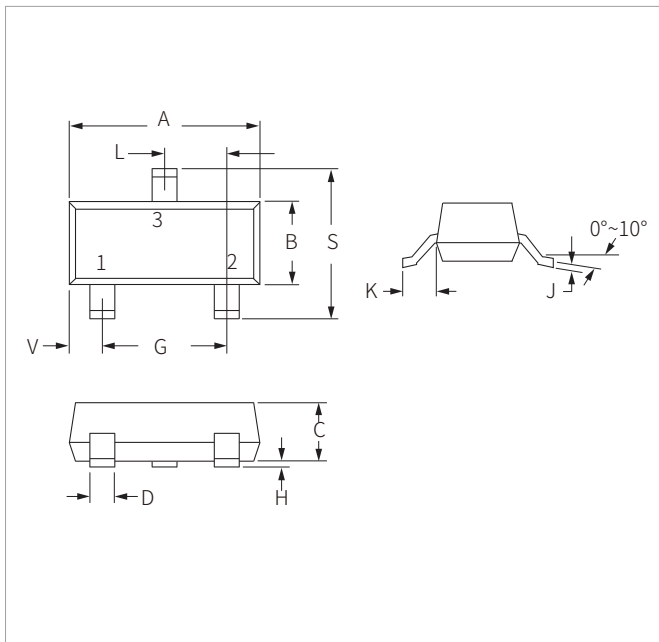

SOT-23 PACKAGE INFORMATION



Ref.	Millimeters		Inches	
	Min.	Max.	Min.	Max.
A	2.80	3.05	0.110	0.120
B	1.20	1.40	0.047	0.055
C	0.90	1.15	0.035	0.045
D	0.37	0.50	0.015	0.020
G	1.75	2.05	0.069	0.081
H	0.01	0.100	0.001	0.004
J	0.085	0.180	0.003	0.007
K	0.35	0.69	0.014	0.029
L	0.89	1.02	0.035	0.040
S	2.10	2.65	0.083	0.104
V	0.45	0.60	0.018	0.024

RECOMMENDED PAD LAYOUT DIMENSIONS

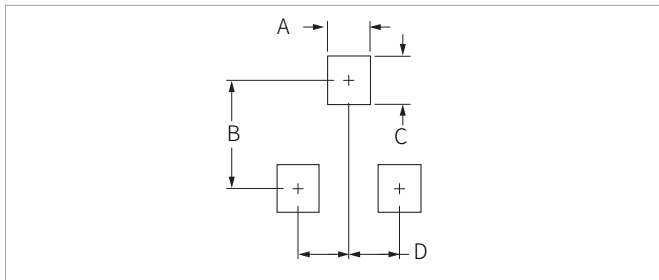

Ref.	Millimeters		Inches	
	Min.	Max.	Min.	Max.
A	0.71	0.97	0.028	0.038
B	1.88	2.13	0.074	0.084
C	0.71	0.97	0.028	0.038
D	0.81	1.07	0.032	0.042

ORDERING INFORMATION

Part Number	Component Package	QTY/Reel	Reel Size
BAV170	SOT-23	3000PCS	7"

To find your local partner within Semiwell' s website : www.semiwell.com.cn

© 2023 Semiwell Microelectronics Co.,Ltd.

The content of this document has been carefully checked and understood. However, neither Semiwell nor its subsidiaries assume any liability whatsoever for any errors or inaccuracies of this document and the consequences thereof. Published specifications are subject to change without notice. Product suitability for any area of application must ultimately be determined by the customer. In all cases, products must never be operated outside their published specifications. Semiwell does not guarantee the availability of all published products. This disclaimer shall be governed by substantive Chinese law and resulting disputes shall be settled by the courts at the place of business of Semiwell. Latest publications and a complete disclaimer can be downloaded from the Semiwell website. All trademarks recognized.